

# HORIZONTAL POWER BOARD (6/10 OUTLET VERSIONS) ASSEMBLY GUIDE

## REQUIRED ITEMS

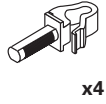

## STEP 1 - FRONT RACK STUD INSTALLATION

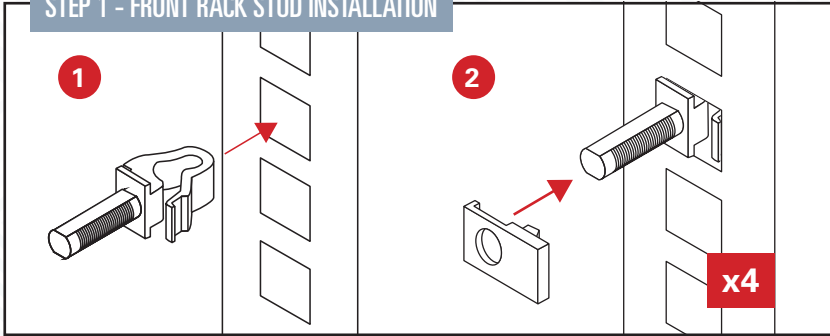

## STEP 2 - SLIDE ONTO RACK STUDS

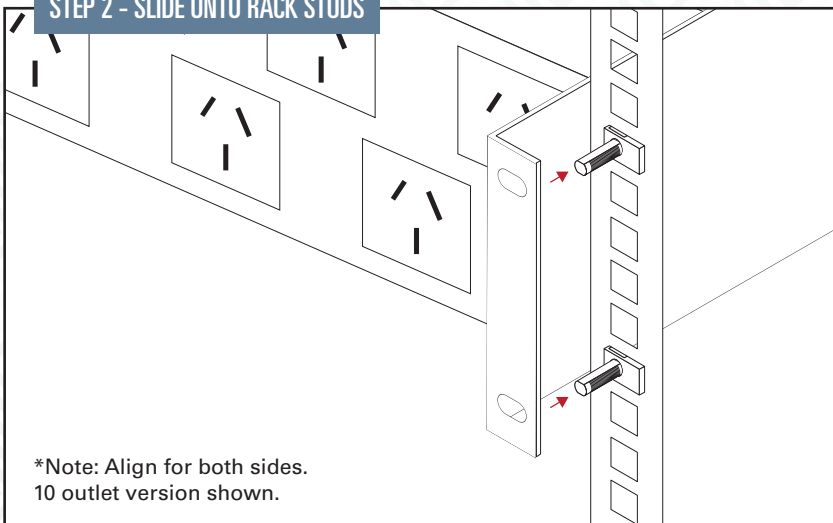

## STEP 3 - TIGHTEN TO LOCK

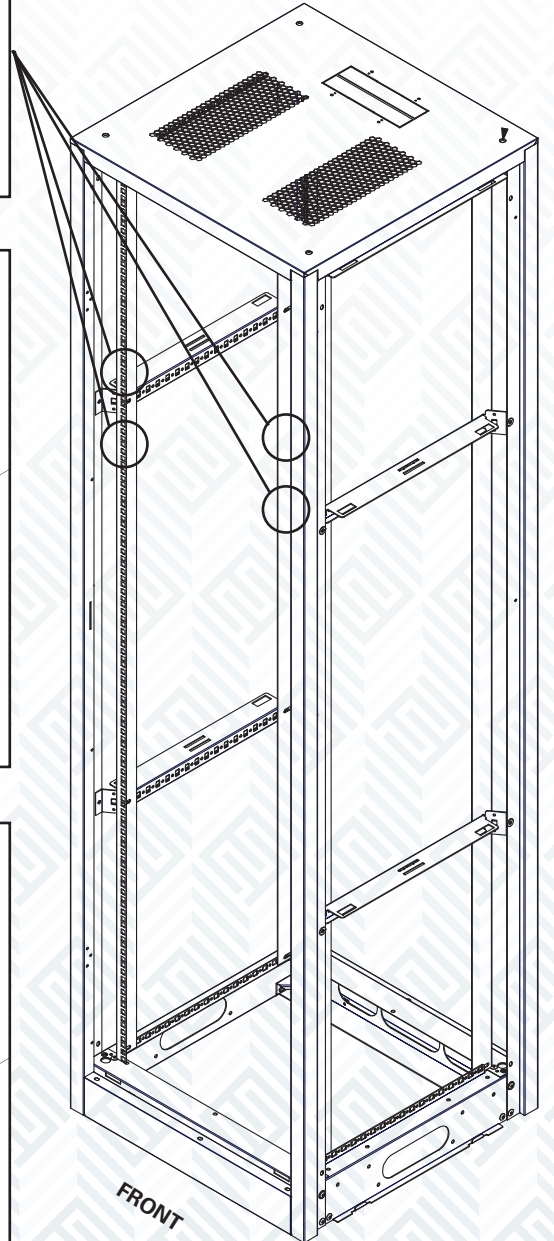
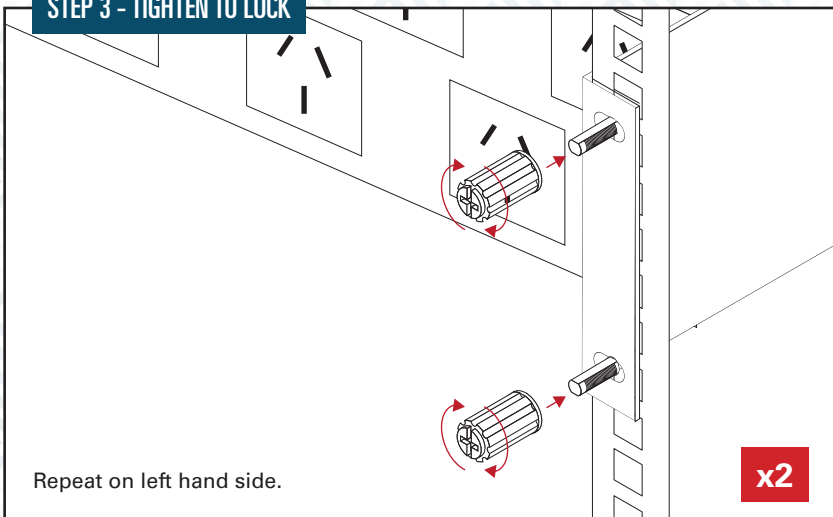

MFB PRODUCTS PTY LTD

105 Lewis Rd  
Wantirna South VIC 3152  
Australia

T +61 3 9801 1044 / +61 3 9749 1922

E sales@mfb.com.au

W www.mfb.com.au

